

WHAT'S ALL THIS STUFF ABOUT GENERATORS?

OR

WHAT TO DO BEFORE THE POWER GOES OUT

SOME GENERATOR FACTS	2
HOW LARGE A GENERATOR DO I NEED?	3
HOW DO I CONNECT THE GENERATOR TO MY HOUSE?	
DIRECT CONNECTION	4
TRANSFER SWITCH CONNECTION	5
WHAT KIND OF FUEL?	6
SAFETY	
OPERATING LOCATION	7
FUEL STORAGE	7
REFILLING	7
MANUAL OR ELECTRIC START	7
CONNECTION	8
MATCHING VOLTAGES	8
APPENDIX A - EXAMPLES AND CALCULATIONS	9
APPENDIX B - WATTAGE RATINGS OF DEVICES	13
APPENDIX C - EXAMPLES OF INSTALLATIONS	15
APPENDIX D - WEB SITES	19

SOME GENERATOR FACTS

Generators come in various sizes ranging from small portable units to large commercial plants on trailers. What you need for emergency backup is something in between.

Your needs (and your pocket book), rather than your wants, should determine what you buy for a generator.

You won't have to run your generator 24 hours a day. You only have to run it during waking hours and most likely not even for all that if the temperature is moderate.

Units suitable for an average house range from 2500 watts to 5000 watts. Prices tend to take a jump over the 5000 watt level.

Smaller ones, in the 1000 to 2500 watt level, allow only one or two appliances to be powered at any one time. Larger ones will support more devices at once and will be built heavier.

Gas and diesel are the most common generator fuels in this area.

Generators under 10,000 watts are usually gas powered, while those over 10,000 watts are commonly diesel.

Do not leave gas in the tank of a gasoline-powered generator for longer than a couple of months without an extender to prevent it from fouling the unit.

Use only the gasoline fuel grade recommended by the manufacturer.

Diesel fuel can be left in the generator or in storage for at least two years.

Furnace oil can be used instead of diesel vehicle fuel.

HOW LARGE A GENERATOR DO I NEED?

The answer to this question is like the reason for giving someone Fast Offering – to sustain life and not to maintain lifestyle.

Operating your entire house can be done but not within the budget of most of us.

Start by listing, on a piece of paper, what you really **must** have to keep reasonably comfortable during a prolonged power outage.

Things like freezer and/or refrigerator to keep your food from spoiling, furnace for heat, microwave to cook with, water pump if you live in a rural area, limited amount of house lighting, television and/or radio to keep posted on local news & weather bulletins, and perhaps the electric water heater.

Once you have all the things listed you need take your piece of paper and pencil and look for the plate on each item giving the power in watts or kilowatts (1 kilowatt = 1000 watts, 1.5 kilowatts = 1500 watts). This is the **wattage**. By each device on your list, write down the figure.

Items like freezers or furnaces will have two wattages although they may not be shown. They have motors, which will require more power (watts) to start, and less once the startup is complete and they are into normal running operation. Use the start or surge wattage for your calculations.

If you can't find the plate then use the figures from Appendix B.

Add all of the individual wattages for the total wattage required. This will show you what the ideal generator is for your needs.

See Appendix A for examples of calculating your generator needs.

HOW DO I CONNECT THE GENERATOR TO MY HOUSE?

Buying a generator and getting it home is not all you need to do to prepare for the next power failure. The middle of a stormy night is not the best time to be looking for the manual.

Safely connecting and operating the generator is the next step.

There are several ways to connect your generator. Some of them are not only illegal, but also highly dangerous. Always observe safety precautions and electrical codes.

DIRECT CONNECTION

The first and simplest is a direct connection to your appliances with extension cords.

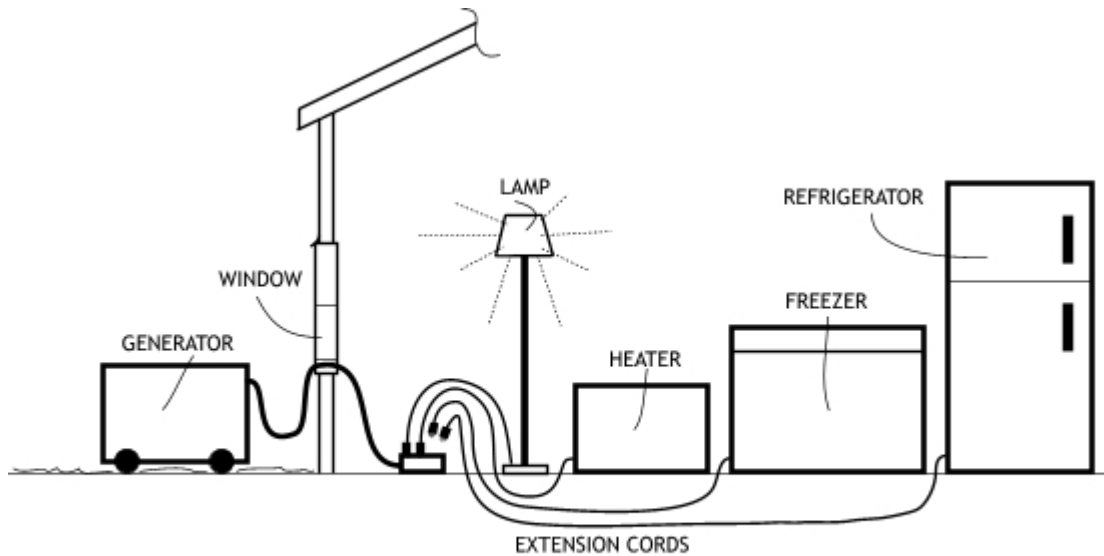

DIRECT GENERATOR CONNECTION METHOD

If you are mainly interested in keeping the food in your refrigerator and freezer from spoiling, buy good quality extension cords of a sufficiently heavy gauge wire. Unplug the appliance from the wall and using the extension cord, plug into the generator outlet.

This method will also let you keep warm with a space heater powered from the generator and provide light from lamps.

It will not let you run your furnace or any other item permanently wired into your house electrical panel.

See example #3 in Appendix A for more information.

TRANSFER SWITCH PANEL

The transfer switch (or generator) panel connects the back-up generator with the electrical system of your home. It is the ideal on/off switching system that allows the homeowner to switch between power provided by the electrical utility and the generator.

A properly installed transfer switch panel allows selected appliances to be powered from your generator.

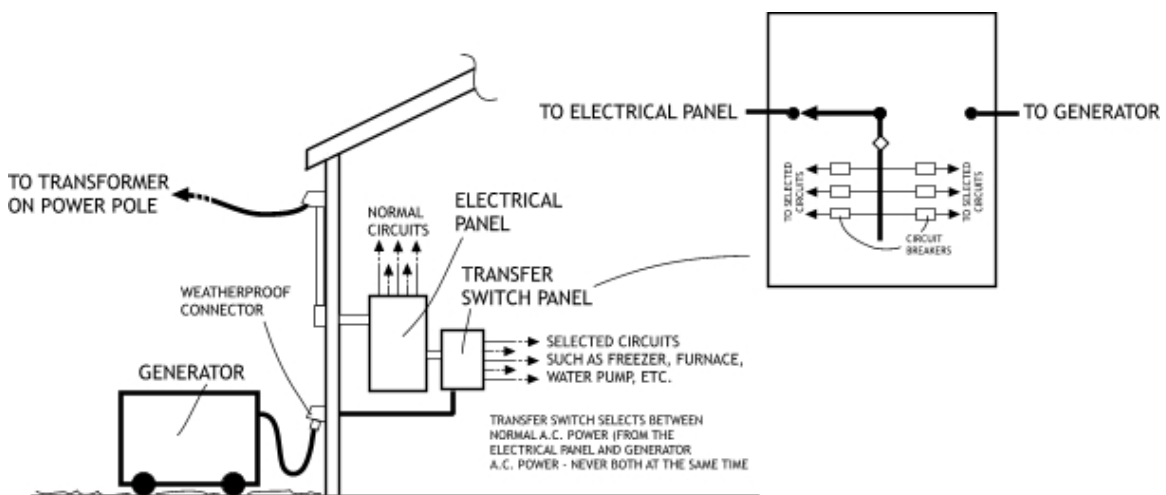

GENERATOR CONNECTION WITH TRANSFER SWITCH

Unless you know exactly what you are doing, have a qualified electrician install the transfer panel and make the necessary wiring changes.

Power from the main electrical panel is fed via a dedicated double-pole breaker of the appropriate amperage rating. If your transfer switch panel has a 30 amp capacity then your main panel breaker should be a 30 amp unit (similarly, if your transfer switch panel is rated for 60 amps then you would use a double pole 60 amp breaker).

WHAT KIND OF FUEL?

The most commonly available fuels in this area would be gasoline, diesel and propane, with the first two being perhaps the better choices in times of trouble.

Of the two fuels, gasoline is the most easily obtained but the hardest to store. Gas will start to break down into engine clogging components after a couple of months unless a stabilizer such as "STA-BIL" is added. According to the manufacturer, with this additive, gasoline shelf life can be extended to fifteen months. Diesel may be stored for up to two years without additives.

If you use gas, rotate it every month by dumping it into your vehicle and refilling the container/s with the correct grade. Use an approved container and clearly mark it "FOR GENERATOR USE ONLY" or something similar.

Generally, gas powered generators are lower in purchase price than diesel. On the other hand, diesel units are heavier built and should last longer.

If you have an oil furnace then this fuel may be used instead of diesel from the service station pump. You save money by not having to pay highway taxes. You also have larger storage capability with your oil tank. Have your furnace service people install a tap to draw off fuel as required.

SAFETY

OPERATING LOCATION

Never operate a generator **inside the house**. Exhaust gasses are produced which will kill.

Operation inside a garage is only safe with the generator near the open main garage door and any door connected to the house closed.

If the operation site is susceptible to theft then chain and padlock the generator to a solid point. Generators are prime targets during a power outage.

Consider installing a wheel kit to make the generator easier to move if you plan to store it in a different location than where you will operate it.

Never operate the generator **in a wet environment**. Electricity produced by any size generator can kill.

FUEL STORAGE

Store the fuel only in approved containers and apart from the generator.

REFILLING

Never refill the generator **while it is running or hot**. Allow 5 –10 minutes for the unit to cool off after shut down.

Fill with clean fuel through a strainer.

Use the fuel grade recommended by the generator manufacturer.

MANUAL OR ELECTRIC START

Generators are available with manual (pull cord) or electric start. The choice is up to you and may depend somewhat on your upper body strength. Electric start models typically cost more and there is the additional care of the battery to consider.

CONNECTION

Connect the generator to the house **only by approved methods**. See pages 4 and 5.

Never feed the output of the generator **into a wall or dryer socket**. Doing it in this manner may feed power out of your house, through the transformer and into the power lines (known as “backfeeding”). This can injure or kill a power company employee working on a “dead” line.

Should the main power source come back on while your generator is providing power, you may be lucky in having only the generator’s protective breaker open. On the other hand, you may not be so lucky and have a destroyed generator.

MATCHING VOLTAGES

If your generator has outlet sockets for both 120 and 240 volts make sure you plug your devices into the correct socket. Failing to do so will damage either the generator or the appliance/s.

Also, be aware that **you cannot take the maximum rated current from both the 120-volt outlet/s and the 240-volt outlet/s at the same time**. The total current (and hence, the total power) must not exceed the maximum generator rating.

See Appendix A, Example #3 for the formula giving the relationship between current and power.

APPENDIX A

EXAMPLE #1

In a couple of months after all the panic generator buying has ended you see a 5 kW (5 kilowatt or 5000 watt) generator at the local hardware store. That must certainly be more than enough to run your entire house, you think. You place a call to the Bishop, the Elder's Quorum President and your home teachers with a request for help to get it home. An hour later the missionaries show up to help you lift it into the back of your utility trailer.

Will it be enough for what you want?

When you get home you figure out you need the following to keep you comfortable during a power outage:

Item	Watts	
1. Refrigerator	2000 (surge)	
2. Freezer	1200 (surge)	
3. Furnace	2300 (surge)	
4. Microwave	800	
5. Electric range	1500	one element
6. Electric oven	3410	
7. Electric water heater	4000	
8. TV	300	
9. Radio	100	
10. Hair dryer	1200	your wife insisted
11. Lights	500	five 100 watt bulbs
TOTAL	17,310 WATTS (17.31 kW)!	

Perhaps you should have bought a few more generators when you had those missionaries to help!!

Or you can be a bit more realistic about what you need.

You don't need to use the electric range or the oven when you have a microwave. Cut 4910 watts from the previous total for a new one of 12,400 watts. Your good wife absolutely refuses to do without her hair dryer – don't even think about it.

1. Refrigerator	2000 (surge)	
2. Freezer	1200 (surge)	
3. Furnace	2300 (surge)	
4. Microwave	800	
5. Electric water heater	4000	
6. TV	300	
7. Radio	100	
8. Hair dryer	1200	
9. Lights	500	five 100 watt bulbs
TOTAL	12,400 WATTS (12.4 kW)	

Maybe the store still has a generator or two left.

You decide that you can heat water in the microwave and take sponge baths instead of running the water heater. This will cut another 4,000 watts and leave you with 8,400 watts.

1. Refrigerator	2000 (surge)	
2. Freezer	1200 (surge)	
3. Furnace	2300 (surge)	
4. Microwave	800	
5. TV	300	
6. Radio	100	
7. Hair dryer	1200	
8. Lights	500	five 100 watt bulbs
TOTAL	8,400 WATTS	

And your wife still won't give up her hair dryer! Looks like we should have bought a bigger generator.

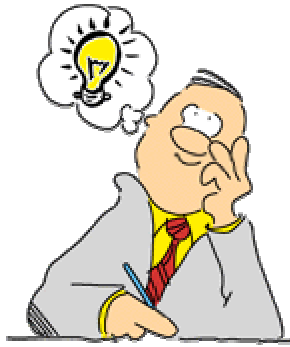

I really only have to operate what I need, when I need it!

What if I operate the furnace for a while until the house is warm then shut it off? Then I can run the fridge and freezer for an hour or so to keep my food from thawing. And when those two are off I can use the microwave to cook the meal while the kids watch tv and the wife dries her hair. We only turn on what lights we really need.

You could even run the electric water heater by itself so you all could have showers.

EXAMPLE #2

Instead of a forced air furnace you have electric wall heaters. After the calculations you find the total watts required are more than you can afford in a generator. You decide to get a space heater with an 1800 watt requirement and wear sweaters instead. Your wife decides she doesn't need a hair dryer since everyone else is in the same predicament.

1. Refrigerator	2000 (surge)	
2. Freezer	1200 (surge)	
3. Space heater	1800	
4. Microwave	800	
5. TV	300	
6. Radio	100	
7. Lights	500	five 100 watt bulbs
TOTAL	6,700 WATTS	

Again, we only run what we need at any given time as a 5,000 watt generator will not support all of the devices at the same time.

Note that a 3000 or 4000 watt generator would support selected combinations of appliances as well.

EXAMPLE #3

You don't want to go to the trouble of having a transfer switch panel installed and decide to use the direct connection method. You plan on buying good quality extension cords, which will handle the necessary current to run the appliances.

$$P = IE$$

Where

P = Power (watts)

I = Current (amps/amperes)

E = Voltage (volts)

Using the refrigerator as an example,

$$P = IE \text{ or } I = P/E \text{ (Power divided by the Voltage)}$$

$$I = P/E$$

$$I = 2000/120 \text{ (E or voltage is 120 volts)}$$

$$I = 16.7 \text{ amps}$$

Purchase an extension cord capable of handling 15 amps. Remember, this current is for the starting or surge current and once the motor is running, the power requirement drops back to a lower value.

Extension cords with a 15 amp rating are standard and can be used for all of the devices in this example. Don't scrimp on these cords. Buy good quality.

EXAMPLE #3 - continued

1. Refrigerator	2000 (surge)	
2. Freezer	1200 (surge)	
3. Space heater	1800	
4. Microwave	800	
5. TV	300	
6. Radio	100	
7. Lights	500	five 100 watt bulbs
TOTAL	6,700 WATTS	

Any generator with a wattage rating of 3000 watts or higher can be used by only plugging in devices where the total watts do not exceed the generator rating (less a 10% de-rating factor). So, if you have a 3000 watt unit, you can provide power for the refrigerator, radio and the lights (total of $2000+500+100=2600$ watts). Running the refrigerator and the space heater along with tv would be too much ($2000+1800+300=3100$ watts).

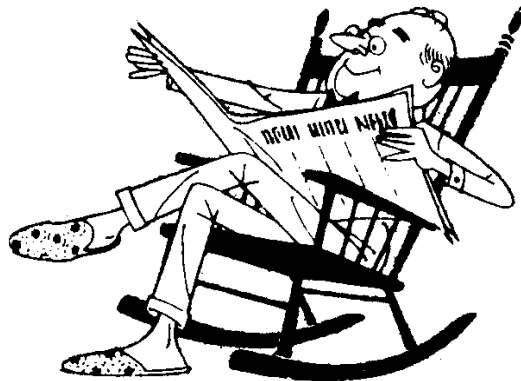

Appendix B

FROM THE CENTRAL MAINE DIESEL WEBSITE

<http://www.centralmainediesel.com/calculator.asp>

Appliance	Rated Watts	Surge Watts
Survival Appliances		
Enter # of light bulbs <input type="text" value="0"/>	75 each	75 each
<input type="checkbox"/> Refrigerator (1/4 HP)	500	2000
<input type="checkbox"/> Freezer (1/4 HP)	600	1200
<input type="checkbox"/> Sump Pump	800	2000
<input type="checkbox"/> Water Pump (1 HP)	1900	5700
<input type="checkbox"/> Water Pump (2 HP)	2500	7500
Heating		
<input type="checkbox"/> Furnace Fan (1/2 HP) *	875	2300
<input type="checkbox"/> Electric Blanket	400	400
<input type="checkbox"/> Space Heater	1800	1800
<input type="checkbox"/> Heat Pump*	4700	12000
Cooling		
<input type="checkbox"/> Dehumidifier	650	800
<input type="checkbox"/> Attic Fan*	300	900
<input type="checkbox"/> Table Fan	800	2000
<input type="checkbox"/> Window Air Conditioner	1200	4800
<input type="checkbox"/> Central Air (10k BTU) *	1500	6000
<input type="checkbox"/> Central Air (24k BTU) *	3800	15000
<input type="checkbox"/> Central Air (40k BTU) *	6000	24000
Family Room		
<input type="checkbox"/> Computer System: CPU, Monitor, Laser Printer	1500	1500
<input type="checkbox"/> UPS System	2000	2500
<input type="checkbox"/> CD Player	100	100
<input type="checkbox"/> VCR	100	100
<input type="checkbox"/> Radio	100	100

<input type="checkbox"/>	Television	300	300
<input type="checkbox"/>	Receiver	420	420
	Kitchen	Rated Watts	Surge Watts
<input type="checkbox"/>	Microwave	800	800
<input type="checkbox"/>	Blender	300	900
<input type="checkbox"/>	Electric Range (1 element)	1500	1500
<input type="checkbox"/>	Toaster (2-slice)	1000	1600
<input type="checkbox"/>	Dishwasher (Hot Dry)	1500	3000
<input type="checkbox"/>	Electric Oven	3410	3410
	Laundry Room		
<input type="checkbox"/>	Iron	1200	1200
<input type="checkbox"/>	Washing Machine	1150	3400
<input type="checkbox"/>	Gas Clothes Dryer	700	2500
<input type="checkbox"/>	Electric Clothes Dryer	5400	6750
	Electric Motors		
<input type="checkbox"/>	1/6 HP Motor	300	850
<input type="checkbox"/>	1/4 HP Motor	400	1150
<input type="checkbox"/>	1/3 HP Motor	475	1325
<input type="checkbox"/>	1/2 HP Motor	650	1800
<input type="checkbox"/>	3/4 HP Motor	900	2500
<input type="checkbox"/>	1 HP Motor	1000	2800
<input type="checkbox"/>	1-1/2 HP Motor	1700	4800
<input type="checkbox"/>	2 HP Motor	2000	5900
<input type="checkbox"/>	3 HP Motor	3200	9000
<input type="checkbox"/>	5 HP Motor	5000	13750
	Other Important Items		
<input type="checkbox"/>	Security System*	500	500
<input type="checkbox"/>	Deep Freezer	500	1000
<input type="checkbox"/>	Hair Dryer	1200	1200
<input type="checkbox"/>	Garage Door Opener (1/3 HP)	750	750
<input type="checkbox"/>	Electric Water Heater*	4000	4000

Appendix C

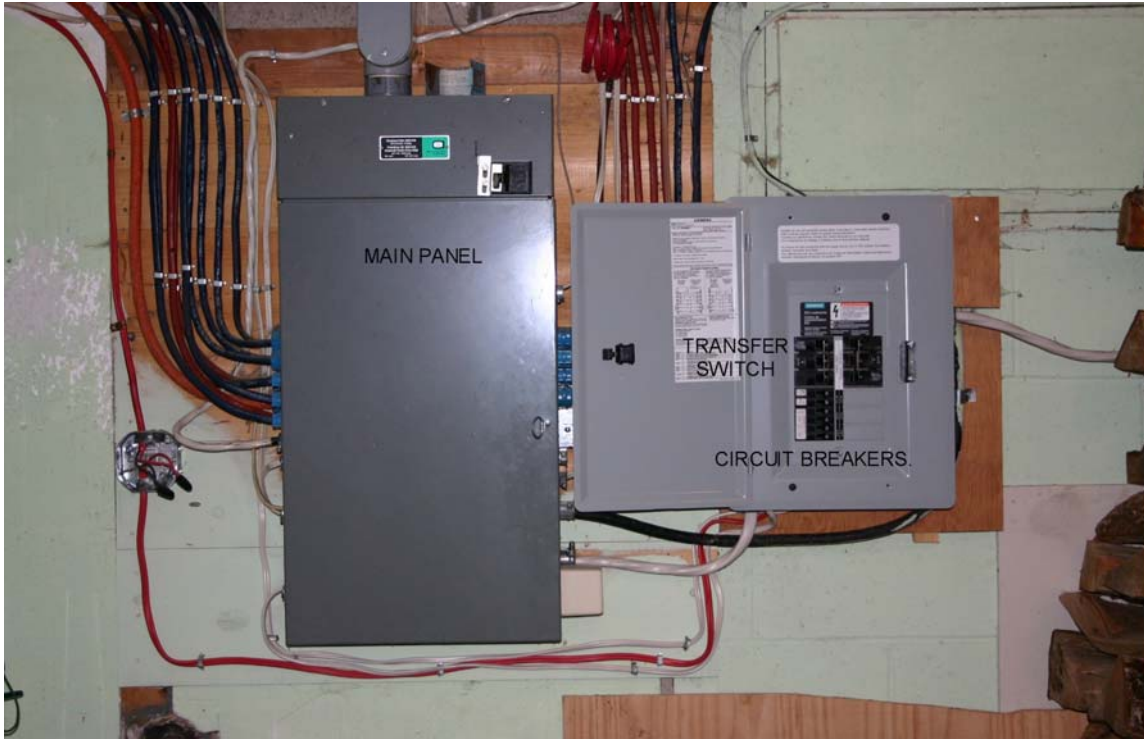

The system above uses a combination transfer switch and breaker panel as shown in the Transfer Switch method on page 4. This unit is manufactured by Siemens (Catalog # EQG660D).

Power from the main panel (power company) comes through the dark cable under the transfer switch panel to the transfer switch. Moving the switch to the other position takes power from the generator fed through the white cable shown entering to the right.

The cover of the transfer switch panel is shown in the open position.

Appendix C - continued



This is an example of a variation of the transfer switch type of installation. It is an older style using a separate transfer switch and sub-panel.

Desired circuits were transferred from the main panel to the sub-panel. A double pole breaker was added to the main panel to provide power through the switch to those transferred circuits.

When the switch handle is in the upper position as shown, power comes from the main panel. When placed in the lower position, power is only available from the generator.

The sub-panel is a standard small breaker panel.

Appendix C - continued



GENERATOR POWER PANELS

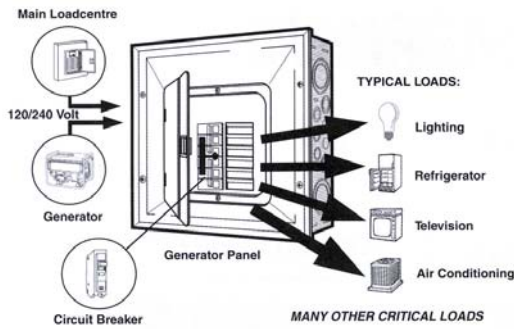

Reliability Plus...Generator Power Panels From Cutler-Hammer

- If safety and reliability are what you need, use Cutler-Hammer's Generator Panel as your standby electrical requirement. The reliability you need even under the most severe conditions.
- Designed by Cutler-Hammer and Hydro specialists to ensure your safety.
- 60A panels now available in a switched or non-switched neutral configuration.
- Power is transferred manually from the main service to the Generator during a power outage. A mechanical interlock is fitted to avoid dual power source feed.

IMPORTANT:
Before installation, consult appropriate electrical codes.
Installation information included in carton.

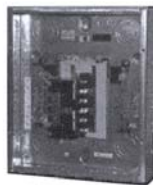

Catalogue Number	Max. Branch Circuit	Dimensions (Inches)		
		H	W	D
30A 120/240V Switched Neutral Generator Panel				
CPL112G3	6/12	16-3/4	14-3/8	3-7/8



Catalogue Number	Max. Branch Circuit	Dimensions (Inches)		
		H	W	D
60A 120/240V Switched Neutral Generator Panel				
CPL112G6	6/12	16-3/4	14-3/8	3-7/8
CPL120G6	14/28	21	14-3/8	3-7/8
CPL130G6	24/48	29-1/8	14-3/8	3-7/8



Catalogue Number	Max. Branch Circuit	Dimensions (Inches)		
		H	W	D
60A 120/240V Non-Switched Neutral Generator Panel				
CPL108GN6	4/8	13	11	3-1/2

This is a scanned page from the EATON/CUTLER-HAMMER catalog showing the combination switch and distribution breaker panels as described on page 4.

Appendix C - continued



Shown above is the front panel of a Siemens generator panel (Catalog # EQG660D). See also, page 4 and page 15.

The transfer switch comprised of two pairs of three ganged circuit breakers is in the centre. These select either the power company supply or the generator as the source, not both.

The individual circuit breakers underneath control the various circuits – furnace, freezer, lights, etc.

Appendix D

WEB PAGES

<http://www.mara.net/~marane/generator/gen.pdf>

This manual in PDF format

http://popularmechanics.com/home_improvement/home_improvement/1998/3/install_backup_generator/print.phtml

Installing a backup generator wired directly into your house circuits by POPULAR MECHANICS magazine. Well written with pictures.

<http://www.centralmainediesel.com/calculator.asp>

This web site contains the calculator shown in Appendix B and allows for on-line calculations. Makes your life easier in case you can't find a pencil and paper.

http://www.pge.com/004_safety/outage_safety/outage_home.shtml
http://www.pge.com/004_safety/004c_storms.shtml

Some general information on what to do before, during and after a power failure. The second web address contains information on general storm preparedness.

<http://www.hondapowerequipment.com/gen.htm>

A U.S. HONDA website covering their models along with operation and safety information.

[http://www.nyseg.com/nysegweb/online.nsf/doc/egs/\\$file/emerggen.pdf](http://www.nyseg.com/nysegweb/online.nsf/doc/egs/$file/emerggen.pdf)

Good general information on generator operation and safety from the New York State Electric and Gas Company.

<http://utilities.dteenergy.com/infoZone/safety/portableGenerator.html>

Basic information on generators and safe operation.

Appendix D – continued

<http://www.powerprotection.org/powergeneration/homewattage.shtml>

Another power calculator.

<http://he.honda.ca/powerequipment/generators/default2.asp>

HONDA Canada website.

<http://www.canadiantire.ca/gateway/generators.htm>

Canadian Tire website for generators

<http://www.goldeagle.com/sta-bil/faqs.htm>

Gasoline fuel stabilizer

<http://www.yamaha-motor.ca/english/>

YAMAHA Canada site. Click on “Power Products” and “Full List”

<http://www.colemanpowermate.com/>

The U.S. site for COLEMAN generators

<http://www.generatorjoe.net/page.asp?id=20>

More information and charts