

MERCURY AMATEUR RADIO ASSOCIATION

MARA - NORTH AMERICA - NORTH EAST



OCTOBER 2007

Newsletter

All Hallow's Even, or Hallowe'en, is a tradition celebrated on the night of October 31, most notably by children dressing in costumes and going door-to-door collecting sweets, fruit, and other gifts, called most commonly trick-or-treating. Scary stuff - better take along your handheld when you go out!

...taken mostly from Wikipedia

CONTENTS

VIEW FROM THE TOP	1
TECH STUFF	2
DI-DAH-DI-DAH-DIT	5



**YOUR QSL CARD COULD BE
UP IN LIGHTS!**



**How about scanning your QSL
card and sending us a copy?**

VIEW FROM THE TOP

As the summer has passed, and the fall leaves start to turn - or in Dave's case, fall to the earth and require raking - it's time to consider the antenna projects completed and those unfinished for which time is fast running out. Fall is an excellent time to get going and get things done, avoiding the winter of I-wish-I-had...

It's also a good time to evaluate how we would continue to operate in an emergency situation. How "field ready" am I, and how quickly could I deploy if needed. This is part of the 'Chapel Challenge' discussed in the previous month's newsletters. Can we deploy assets at facilities to lessen having to fudge an installation in a time of crisis? I have an 80 meter dipole up between trees at my chapel, and even though I will take it down

soon, the support lines will remain in place and be readily available if my antenna, or someone else's needs to go up in a hurry. I also now have a painter's pole, J-pole antenna, coax, hose clamps and nylon ties ready for emergency setup of VHF/UHF operations.

When a crisis comes, we may be operating from our homes for a period of time. I'm sure you have considered methods of operation which will help you stretch your operating endurance. But have you considered how long you could stay in your dwelling for a number of different scenarios of emergency? Food and water you probably have a good lock on. But what about security, heat, and sanitation? What will keep your family occupied during the crisis? Kids today are so used to electronic devices for entertainment; I needed to have a plan for them as well as us as adults. How about a few old fashion board games? I have a liking for spinner dominos. Morale will be as important as food if we are without public services for an extended period of time.

Well, enough of the doom and gloom for this month. Children are back in school (yeah), and seminary (yeah?). Enjoy the fall colors and join us on Saturday mornings for our regular 80 meter net.

73
Bruce, V.P., VE, N3IA

ARE YOU ON THE MARA-NE E-MAIL REFLECTOR?

It's not just for MARA members!

Anyone who is an LDS amateur radio operator can sign up!

TECH STUFF

SIMPLE FIELD STRENGTH METERS

PART 1 – BASIC CIRCUITS

I've always loved the idea of getting something for nothing and this project just about fits that category - a device that never needs batteries and works without a power cord.

A field strength meter (FSM) provides an indication of the presence of radio frequency (RF) energy, and the passive variety is about the simplest piece of RF test equipment that you can build.

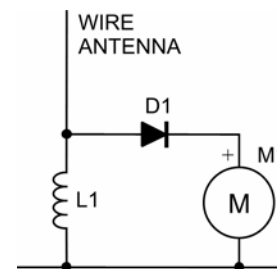

Figure 1 - Really basic - I did say they were simple!

FSM's are frequency insensitive over a wide range and derive their power from the detected RF. They are most useful where an indication of a change in level is more important than the actual strength of the signal.

You can buy a commercially built unit for as low as \$39.95 at MFJ or a Bird 4041 which goes for \$336. As with a lot of things in life, you likely get what you pay for!



MFJ-801 - usable from 100 KHz to 500 MHz



Coaxial Dynamics 7610 - range of 1 to 3000 MHz

For what we as hams need, a homebrew version will likely meet all of our requirements. It usually comes down to:

- a. Is this @#^&## thing transmitting? or,
- b. Did this change make things better or worse?



Bird 4041 - from 1 to 1000 MHz

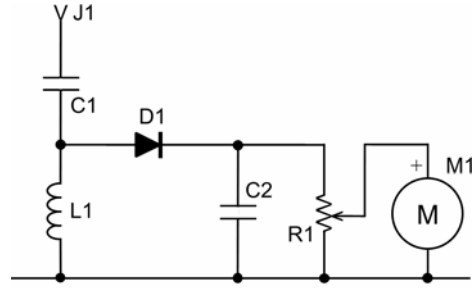

C1, C2 - Capacitor - .001 to .05 μ F
 D1 - Diode - see text
 J1 - Jack - antenna
 L1 - Inductor - 0.5 to 1 mH
 M1 - Meter - 50 to 250 μ A
 R1 - Resistor, variable - 25K to 1M

Figure 2 - Another FSM circuit - Substituting a resistor (100K - 1M) for inductor L1 lowers the amount of voltage available to the meter.

All field strength meter circuits work by converting RF signals present at the input into a DC voltage. This voltage drives an indicator - either digital or analogue - and typically, a variable control is included to adjust the sensitivity.

PARTS

Any metal or plastic case of a suitable size may be used to house the FSM. Just make it stable enough so that it won't accidentally fall over and damage the meter movement.

New meter movements are usually very expensive, so look for one from a junker CB radio (which likely has all the parts you need, except for the case!), an old standing wave ratio (SWR) meter, or a tape recorder. Aim for a movement of 50 μ A to 250 μ A. A transistor amplifier could be added and a higher current movement (1-10 mA) used. Perhaps we'll look at that in a future column. Radio Shack used to have a Micronta 50 μ A meter for a decent price but I don't see it listed on their web site. MFJ sells their meters separately as parts and priced very reasonably. Unfortunately, they don't give any specs or show any pictures on their

web site so you'll have to contact them for information.

The diodes should be germanium (1N34A or similar). Low power Schottky (1N5711 or similar) will work but give less than half of the meter deflection of germanium. Resist the temptation to use silicon diodes, such as the common 1N4148. The voltage required for them to conduct is in the order of 0.7 volts instead of 0.2 volts for the others, making less available to drive the meter. If you have a selection of diodes, pick one (or two) that give the highest meter deflection.

If you want to slow the meter's response to keyed RF, connect a capacitor across the meter terminals. Experiment with different values (0.5 μF and up) until you get the delay/decay you want.

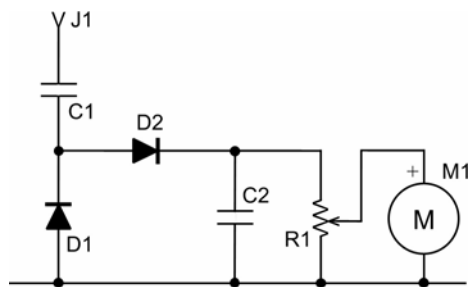

C1, C2 - Capacitor - .001 to .05 μF
 D1, D2 - Diode - see text
 J1 - Jack - antenna
 M1 - Meter - 50 to 250 μA
 R1 - Resistor, variable - 25K to 1M

Figure 3 - Replacing the inductor with another diode for a voltage doubling circuit gives the highest meter reading of all the circuits tested.

Use a short piece of wire, twelve inches or so, for an antenna. Lengthening it will produce a higher meter reading but don't make it so long that your meter falls over!

If you have an old analogue V.O.M. test meter (you know - the one with the needle thingy!), you can use it for double purpose; first as a regular test meter to check voltages and continuity around the shack, and second, as the meter movement for a

meter-less FSM. Set the meter to the μA position, connect the probes (watch the polarity!), and read away.

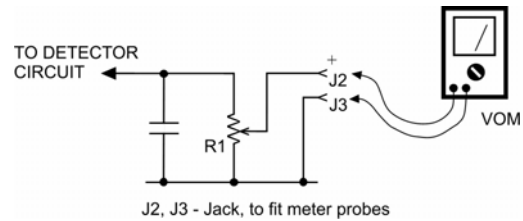

Figure 4 - Using a separate meter

If your old V.O.M. suffers from blown innards, but the meter movement itself is still working, strip out the insides and replace them with one of the detector circuits shown here. Glue a piece of plastic to cover the hole where the switch used to be (if needed), and use that space for the sensitivity control.

WIRING

Use a printed circuit board if you want to make your own, either by resist pen or laser printer transfer. One of the small experimenter boards from Radio Shack, or other suppliers, also works well.

TESTING

Test the FSM by keying your two meter handheld nearby. Gradually turn up the sensitivity control until you obtain a reading on the meter. No meter deflection means it isn't working! Check your parts placement. Recheck your soldering. Look for joints that are improperly soldered or not soldered at all. If the meter indication is backwards, the meter or the diode (or diodes) may be wired in reverse.

When using the FSM on HF, keep it separated from the rig and tuner so that you are seeing transmitted energy from the antenna and not something directly from the

gear. That way, any change you make in tuning will show correctly as a change in antenna radiated power.

When doing comparisons, make sure the FSM stays in the same spot, and if you are holding it, be sure to stand and hold it in the same way. You might find it works better to stand the unit off by itself, keeping your body at some distance so that you don't upset the readings.

Comparative testing on all of the circuits shown was done using an old RF signal generator with a top frequency limit of 52MHz.

Further testing of the circuit in figure 3 has the sensitivity climbing as the frequency increases.

OTHER IDEAS

HEATHKIT used a novel idea for an internal antenna in their HD-1426 FSM, one apparently etched on printed circuit board. If you use a plastic case, it's something to consider. They also had provision for an external antenna. No values for the inductor (RFC1) or the meter were given in the manual, but substitutions based on the other circuits shown previously should be sufficient.

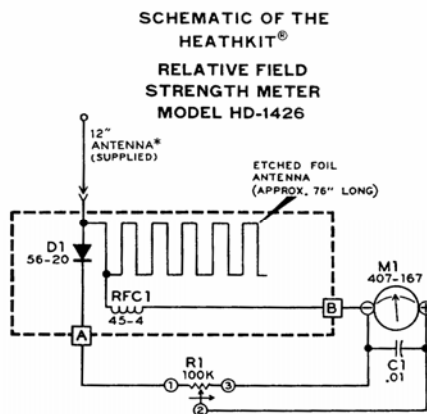

Figure 5 – Heathkit HD-1426

Figure 6 shows a circuit from the August 2002 issue of QST Magazine. I bread-boarded it and found that it was less sensitive than the circuit in figure 2.

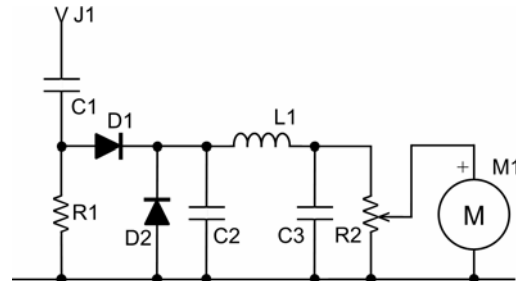

Figure 6 – More parts does not necessarily mean better!

Using resistor R1 in place of an inductor means less voltage at the meter. Diode D2 is in the wrong place for a voltage doubler and did nothing to increase the reading on the meter. Adding L1 and C2 made no difference either. There was a "feedback" correction in the September 2002 issue which moved diode D2 over in parallel with resistor R1 (making it into a voltage doubler) and saying that capacitor C1 was not required (which is true as its function is to block any DC voltage) .

USE WHAT YOU'VE GOT

As you can see from the various circuits, exact parts values are not required. Check your junk box; see what you have that's the same, close to the same, or 'maybe might work', and warm up the soldering iron. Who knows - you might build a better one!

IN THE NOVEMBER ISSUE...

PART 2 OF THE SIMPLE FIELD STRENGTH METER - CONSTRUCTION DETAILS WITH PICTURES (FOR THOSE WHO HATE TO READ!).

MORE CHAPEL CHALLENGE STUFF.

DI-DAH-DI-DAH-DIT

"To invent, you need a good imagination and a pile of junk."
- Thomas Edison

THE JUNK BOX!

Ah, the memories those words can bring back to those of us who remember such things.

When we were young and just getting started in ham radio, we wondered how anyone could ever build anything without ordering from some place like Allied Radio (which eventually became Allied Radio Shack and then Radio Shack).

If we were lucky, we found a nearby ham who helped us start our own collection with some parts to get us going or to finish up some project. Or maybe we hounded family, neighbours, and friends for old radios and televisions to strip for parts.

My mother was happy to see me move to a place of my own so she could finally clean my bedroom without all of the boxes of "stuff" getting in the way.

Chic, WA2USI, from what I've heard, had one the rest of us can only dream about. Every once in a while he would mention about someone asking him if he wanted a generator or a solar panel array, or some such thing.

I've cleaned mine out several times over the years and gave it away as I moved from place to place, but it always seems to grow back again. The trick is to keep a few good parts as "seed stock".

I was searching through the various boxes and bags and bins that make up my junk box the other day, looking for a particular part that I know I have... somewhere... and what should I come across but the first transistor I ever bought – anyone use a 2N107 – if I can ever find it again?

Until next month,

VE1VQ